

KAPP TECH2870 Wilderness Place
Boulder, CO 80301
(303) 447-1130**KAPP CBN GRINDING WHEEL**DATA SHEET FOR
EXTERNAL GEARS

Company Name: _____

Part/Tool #: _____

Sheet 1 of 5:

Directions for completing these forms: KAPP CBN Profile Grinding Wheels are designed and manufactured according to theoretical gear data. Consequently, the customer is able to specify the desired tooth form. To define the grinding wheel, we request your completion of the forms below. Please cross out the data that does not apply. Data to be determined by the manufacturer should be marked with "xx".

Machine Type (Model)	
Kapp Machine No. (Serial #)	
Type of Grinding Arm/Spindle	
Grinding Wheel Diameter	
Designation of Workpiece	
Workpiece No.	
Customer Tool # (Code)	
Type of Operation (Circle one)	FINISHING SEMI-FINISHING ROUGHING

GEAR DATA UNITS (inch / mm)

		Spur Gear	Helical Gear
Number of Teeth	z		
Normal Diametral Pitch	DP_n		
Normal Module	M_n		
Normal Pressure Angle	α_n		
Helix Angle	β	0	
Measurement over Balls / Pins	M_{dk}	max.	
	M_{dr}	min.	
Ball / Pin diameter	D_m		
Span measurement over ($k= \underline{\hspace{1cm}}$) teeth	W_k		

REMARKS:

DATE:

Name:

CONFIGURATION OF ROOT FILLET

Please fill in data for one of the corresponding figures on sheet 3 or 4.

1. Ground Root Fillet

Caution:

Smallest root radius possible
 $h_f = 0.012''$ (0.3 mm)

Give dimensions in
transverse plane.

1.1 One full fillet radius h_f

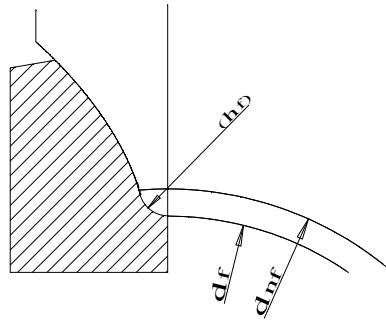

1.2 Two fillet radii with flat root h_f

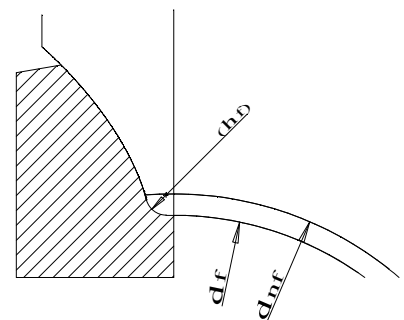

Root diameter	d_f	max.	max.
	d_f	min.	min.
Form diameter	d_{nf}	max.	max.
Root fillet radius	h_f	max.	max.
	h_f	min.	min.

2. Root Not Ground (with step)

Caution:

Smallest root radius possible
 $h_f = 0.012''$ (0.3 mm)

Give dimensions in
transverse plane.

2.1 Full radius h_f on grinding wheel

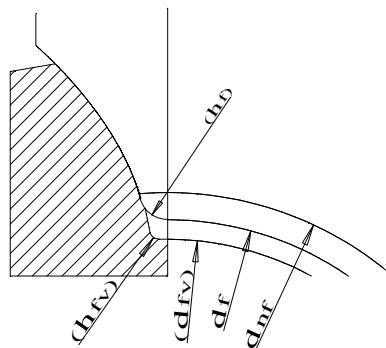

2.2 Two radii h_f on grinding wheel

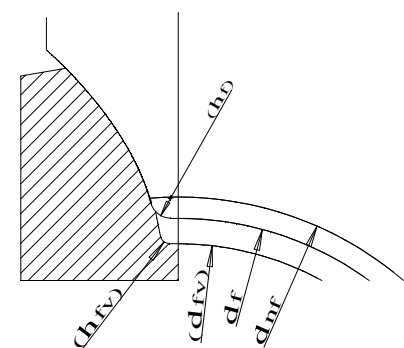

Theoretical root ground dia (value must be defined)	d_f		
Form diameter	d_{nf}	max.	max.
Root fillet radius	h_f	max.	max.
	h_f	min.	min.

NOTE: Premachining data to be completed in section "Pre-Machining", sheet 5

DATE:	Name:
-------	-------

CONFIGURATION OF ROOT FILLET

Please fill in data below the application sketch

3. No grinding of root fillet

3.1 Premachined with Protuberance

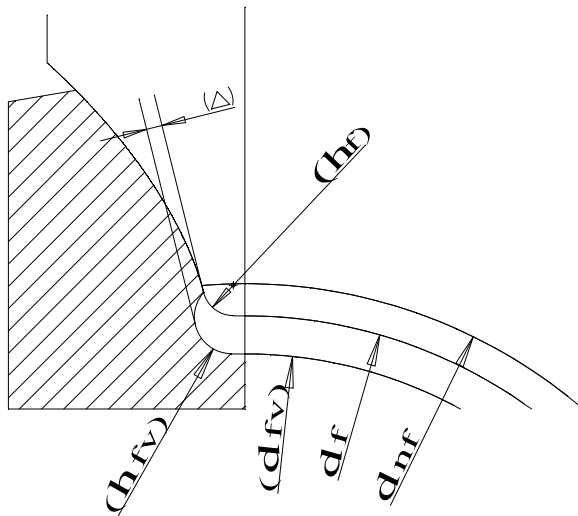

Theoretical root ground diameter (Value must be defined)	d_f	
Form diameter	d_{nf}	
Premachined root diameter	d_{fv}	
Root fillet radius	h_{fv}	
Undercut	Δ	

Caution: Smallest radius on grinding wheel $h_f = 0.012''$ (0.3 mm)
Give dimensions in transverse plane.

DATE:

Name:

CONFIGURATION OF TIP

Please fill in data under applicable sketch.

1. Without tip chamfer

Caution:

Give dimensions in transverse plane.

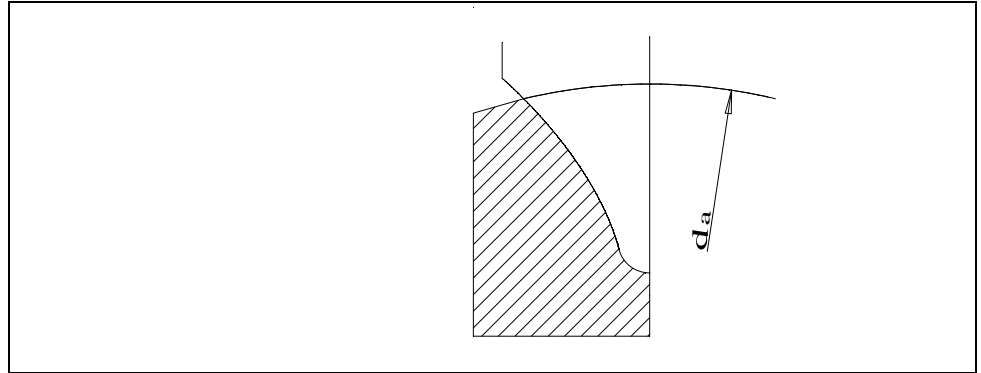

Tip diameter	d_a	max.
	d_a	min.

2. With chamfer at tip

Caution:

Minimum radius possible
 $R_k = 0.03''$ (0.8 mm)

Give dimensions in transverse plane.

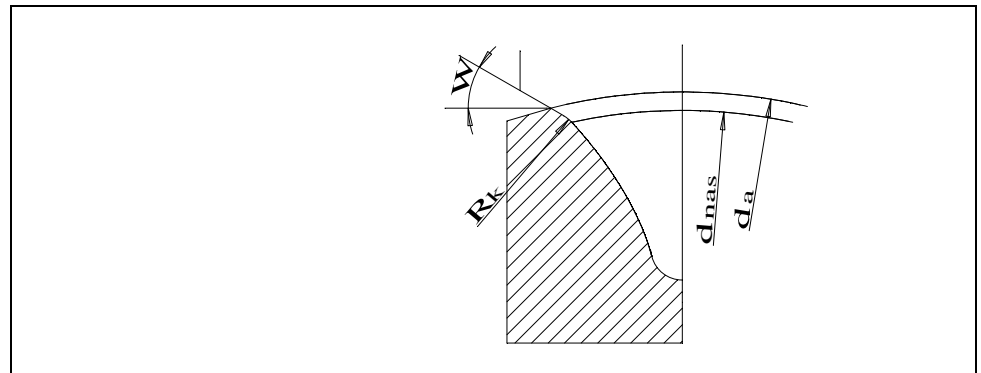

Tip diameter	d_a	max.
	d_a	min.
Form diameter at tip	d_{nas}	
Tip radius	R_k	
Tip break relief angle	W	

Premachining Data (Index "v")

Measurement over balls / pins	M_{dkv}	M_{drv}	max.
	M_{dkv}	M_{drv}	min.
Ball / Pin diameter	Dm		
Span measurement over k teeth	W_{kv}		max.
	W_{kv}		min.
Number of teeth in span	k		
Root diameter	d_{fv}		max.
	d_{fv}		min.
Fillet radius	h_{fv}		max.
	h_{fv}		min.

DATE:

Name: